



Cat[®] TL1255D

TELEHANDLER

Specifications

Engine

Model*	Cat [®] C4.4 ACERT™	
Gross Power (Basic)	106 kW	142.1 hp

*Meets U.S. EPA Tier 4 Final emission standards.

Weights

Operating Weight	15 586 kg	34,361 lb
------------------	-----------	-----------

Operating Specifications

Rated Load Capacity	5443 kg	12,000 lb
Maximum Lift Height (o/r Down)	16.6 m	54.6 ft
Maximum Forward Reach	12.8 m	42 ft
Frame Leveling	10°	
Top Travel Speed	33 km/h	20.5 mph
Capacity at Maximum Height (o/r Down)	2268 kg	5,000 lb
Capacity at Maximum Reach (o/r Down)	1587 kg	3,500 lb
Turning Radius over Tires	4.3 m	14 ft
Drawbar Pull (Loaded)	113.9 kN	25,605 lb

Hydraulic System

Variable displacement load sensing axial piston pump		
System Operating Pressure	260 bar	3,771 psi
Auxiliary Hydraulic Pressure	228 bar	3,307 psi
Auxiliary Hydraulic Flow	95 L/min	25 gal/min

- Auxiliary Hydraulic Circuit used for all attachments equipped with cylinders or other hydraulic components.

Service Refill Capacities

Fuel Tank	145 L	38 gal
Diesel Exhaust Fluid (DEF) Tank	21.5 L	5.7 gal
Hydraulic System	189 L	50 gal

Tires

Standard	400/75-28 Duraforce	
Optional	400/75-28 Foam Filled	
	14.00-24 Solid	
	17.5 × 25 16PR Air	
	17.5 × 25 12PR Foam Filled	

Transmission Speeds

Forward	4 speed
Reverse	3 speed

Boom Performance

Boom Up	16.7 Seconds
Boom Down	14.4 Seconds
Tele In	16.3 Seconds
Tele Out	18.5 Seconds

Axles

- Trunnion mounted planetary 55 degree steer axles.
- High bias limited slip differential on front axle.

Brakes

- Service Brakes are inboard wet disc brakes on front and rear axles.
- Parking Brakes are wet disc, spring applied hydraulic release on front axle.

Work Tools

	Includes	Includes
Hydraulic IT Coupler	Auxiliary Electrics	Auxiliary Electrics
Pallet Forks	(2) 1525 mm, 60 mm × 150 mm (2) 1220 mm, 60 mm × 125 mm	(2) 60 in, 2.36 in × 6 in (2) 48 in, 2.36 in × 5 in
Lumber Forks	(2) 1829 mm, 50 mm × 150 mm	(2) 72 in, 2 in × 6 in
Fork Extensions*	2300 mm	90 in
Cubing Forks	(2) 1220 mm, 50 mm × 50 mm	(2) 48 in, 2 in × 2 in

Carriages:

Standard Tilt	1270 mm	50 in
Wide Tilt	1829 mm	72 in
Side Shift	1220 mm	48 in
Standard Rotate	1270 mm	50 in
Wide Rotate	1829 mm	72 in
Swing	100°, 1829 mm, 4536 kg Capacity, 2268 kg Swung	100°, 72 in, 10,000 lb Capacity, 5,000 lb Swung
Swing	180°, 1824 mm, 5443 kg	180°, 72 in, 12,000 lb
Dual Positioning	1270 mm	50 in

*For use with 1829 mm (72 in) Lumber Forks.



TL1255D Telehandler

Dimensions (All dimensions are approximate.)

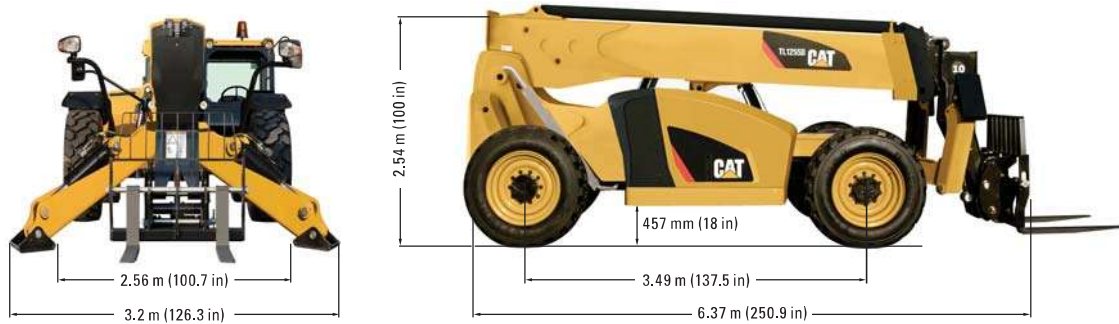

Load Chart and Dimensions

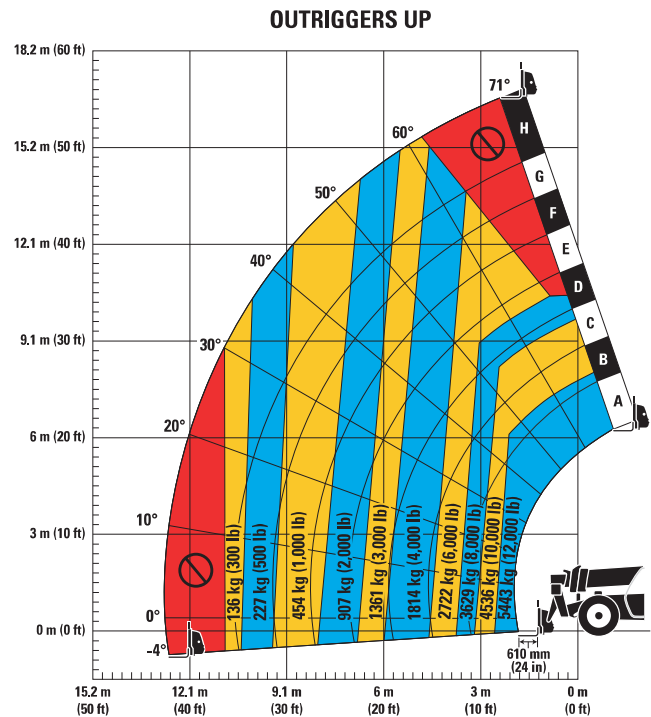
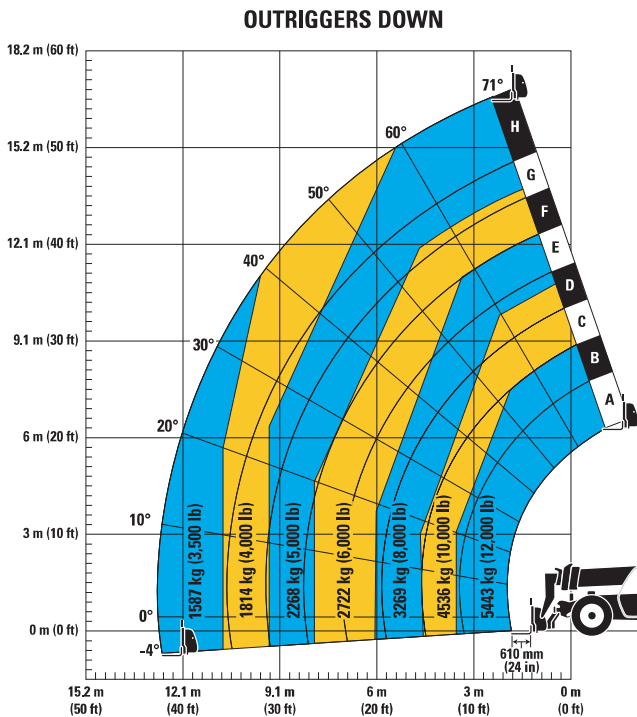

IMPORTANT

Rated lift capacities shown are with machine equipped with carriage and pallet forks. The machine must be level on a firm surface with undamaged, properly inflated tires. Machine specifications and stability are based on rated lift capacities at specific boom angles and boom lengths. (If specifications are critical, the proposed application should be discussed with your dealer.)

DO NOT exceed rated lift capacity loads, as unstable and dangerous machine conditions will result.

DO NOT tip the machine forward to determine the allowable load.

Use only approved attachments with proper material handler model/attachment load capacity charts displayed in the operator's cab.

U.S. OSHA requires all rough terrain forklift operators be trained according to U.S. OSHA 29 CFR 1910.178 (1).

Due to continuous product improvements, machine specifications and/or equipment changes may be made without prior notification. This machine meets or exceeds ANSI/ITSDF B56.6-2011 as originally manufactured for intended applications.

For more complete information on Cat products, dealer services, and industry solutions, visit us on the web at www.cat.com

© 2015 Caterpillar
All rights reserved

Materials and specifications are subject to change without notice. Featured machines in photos may include additional equipment. See your Cat dealer for available options.

CAT, CATERPILLAR, SAFETY.CAT.COM, their respective logos, "Caterpillar Yellow" and the "Power Edge" trade dress, as well as corporate and product identity used herein, are trademarks of Caterpillar and may not be used without permission.

AEHQ7473-01 (10-2015)
Replaces AEHQ7473

