

## FR™ Series: FR 25-35 76" Wheelbase LP-powered liftruck Capacity: up to 35,000 lbs. @ 24"

### FR™ Series liftrucks®

The FR™ Series liftruck® is designed for mobility, strength and effortless handling with an extendable frame to increase loading capacity. Paired with a removable boom, the FR™ Series liftruck® is the ultimate tool for moving heavy machinery safely and effortlessly.

### Chassis

- Extending counterweight chassis
- Removable/Stackable counterweights for greater flexibility and ease of transport
- Chassis tie-down points for transporting

### Operator environment

HOIST® engineers designed the FR 25-35™ Series for maximum productivity, with a cab environment configured around the fatigue-reducing needs of operators.

- Rubber-mounted cab, isolated from the frame to reduce vibration and noise with levels as low as 77 db
- Fully adjustable semi-suspension seat equipped with retractable seat belt.
- Optional "Air-Ride" seat with pneumatic lumbar support and fully adjustable backrest height for added comfort
- Left hand operator position
- Non-skid steps for easy entry/exit design from left side of the truck
- Padded floor mat
- Tilt-steering column
- Illuminated digital instrument display
- "Soft-touch" hydraulic levers
- On-board capacity calculator
- Horn button and steering knob mounted on steering wheel

### Engine

- Standard GM 3.0L L4 Engine
- LP gas standard (tank not included)
  - EZ-mount, LP tank bracket
- Dual fuel standard

### Transmission and drive axle

- 2-speed hydrostatic drive with variable RPM control
- Externally mounted charge pump and integral filter allow for easy maintenance

- Drive: heavy-duty, planetary wheel ends designed for high load capacities, extended service life and reduced maintenance. All gears are heat-treated, precision-ground

### Hydraulic system

Soft-touch control levers allow smooth, comfortable, controlled operation.

- Load-sensing, on-demand system provides smooth and reliable control while limiting demand on the powerplant
- Piston pump provides superior control and quiet operation
- Fuse in lift cylinder protects against sudden loss of pressure. If lift hose breaks, lift cylinder locks safely in position

### Steering system

Heavy-duty steer axle features heavy alloy steel plate sections around single, double-acting cylinder.

- Maximized steering angles provide maximum maneuverability in tight areas while maintaining directional tracking of tire, with no scrubbing or premature tire wear

### Brakes

- Hydrostatic dynamic braking

### Mast design

Heavy-duty nested rail mast provides superior visibility and full capacity at maximum lift heights.

- Contact the factory for special mast requirements

### Carriages

Pin-style carriage allows superior visibility for the operator and maximizes productivity.

- Integral side-thrust rollers provide uncompromised strength and reduce mast wear
- Available carriage configurations include:
  - Fork positioning carriage
  - Side-shifting carriage (under load)
  - SS/FP carriage

### Boom

- Boom stand for facilitating quick change operation. Collapsible for transport.

- Hydraulically powered multi-stage telescopic boom
- High-strength adjustable composite wear pads
- Quick change system requires no tools to switch between boom and forks
- 'Under Pressure' hydraulic quick disconnects

### Forks

Pallet style forks are standard on all trucks. Custom sizes available upon request.

### Options

- Remote control for all vehicle functions
- Air ride seat
- Back-up camera/monitor
- Customer specified chassis color

*Consult your authorized Hoist representative for additional options*

### Serviceability

The HOIST® FR 25-35™ Series liftruck® is engineered with your mechanic in mind: all components are well-placed for easy access and quick maintenance:

- Hydraulic Diagnostic Multi-Gauge standard on all trucks
- Hinged engine cover and removable floor panel provide excellent access to powertrain
- Hydraulic pumps, hoses and tubes and wiring harness are accessible and easy to inspect

### Safety

The FR 25-35™ Series chassis is painted high-visibility "HOIST® yellow". The mast and over-head guard are painted anti-glare black. The truck complies with all currently valid ANSI, OSHA, CE, and EU directives for industrial trucks, and arrives standard with the following:

- Audible backup alarm
- Two adjustable headlights
- Amber strobe warning light



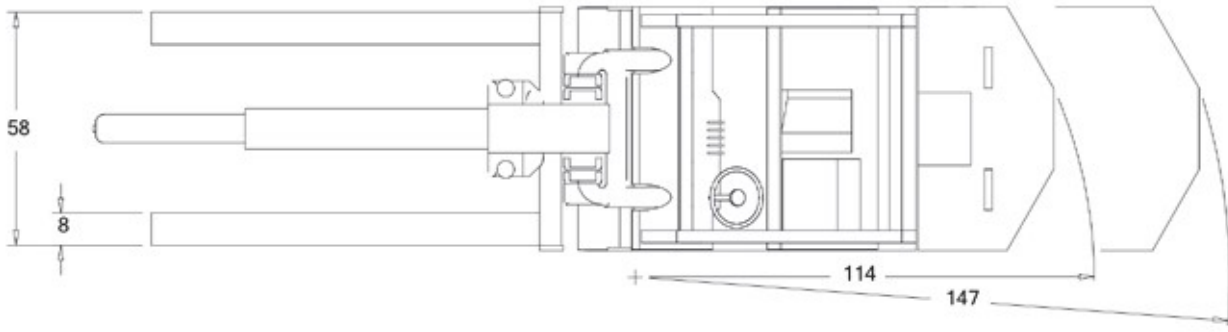

## FR™ Series: FR 25-35 76" Wheelbase



### FORKS ONLY

Counterweight Extension (in)	Load Center (in)	# of Slabs	Lift Capacity (lbs)
0.0 (76" WB)	24.0	0	16,300
0.0 (76" WB)	24.0	6	24,300
36.0 (112" WB)	24.0	0	24,000
36.0 (112" WB)	24.0	6	35,800

### BOOM ONLY

Counterweight Extension (in)	Load Center (in)	# of Slabs	Lift Capacity (lbs)
0.0 (76" WB)	24.0	0	12,400
0.0 (76" WB)	24.0	6	18,800
36.0 (112" WB)	24.0	0	18,500
36.0 (112" WB)	24.0	6	28,000

Consult your authorized Hoist representative for a comprehensive capacity table including extended load centers and alternative slab counts and counterweight extensions.

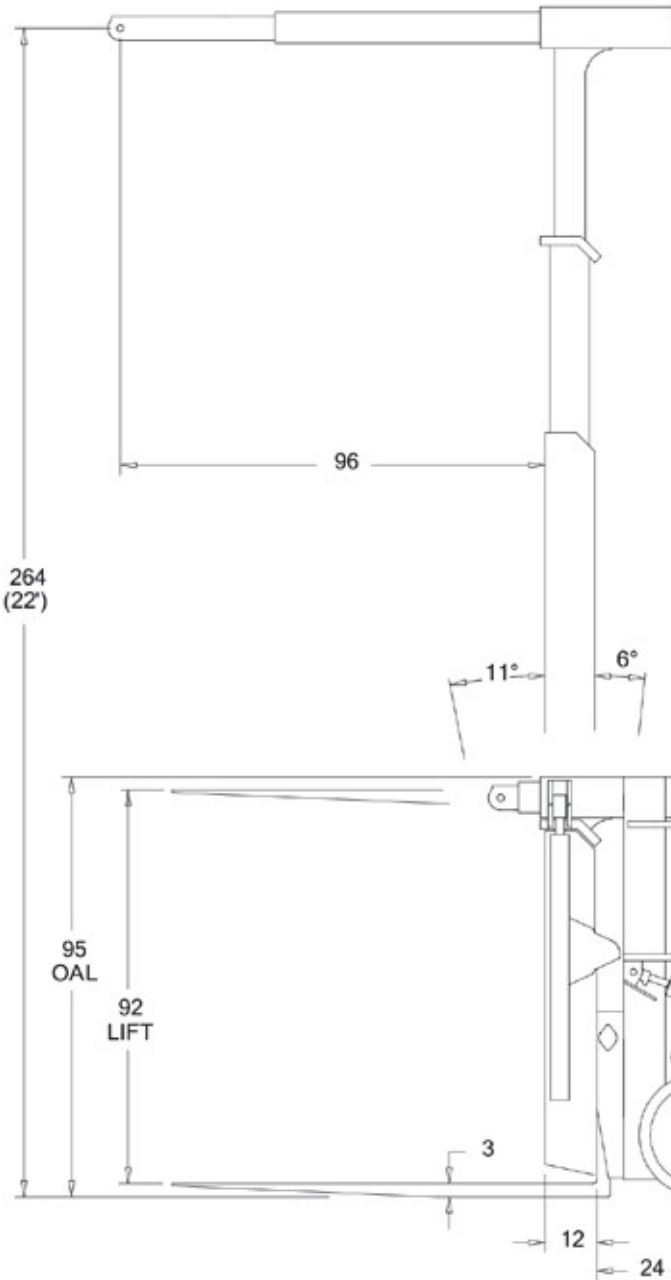

**Hoist Liftruck Mfg. Inc.**  
**6499 West 65th Street**  
**Bedford Park, IL 60638**  
**800-367-5600 (USA)**  
**708-458-2200 (International)**  
**Fax: 708-458-1176**  
**www.hoistlift.com**

The HOIST® product line is full of rugged and efficient materials-handling solutions for every aisle, dock and corner of your facility. To learn more about HOIST® products, log on to the Web at [www.hoistlift.com](http://www.hoistlift.com) or call us directly at 800.367.5600.

**Legendary reliability:** Built for robustness and designed to last, a HOIST® liftruck® will provide reliable service in the most heavy-duty applications, day after day, year after year.

**Ergonomic consideration:** HOIST® engineers design each operator environment for ease of use, superior visibility and comfort.

100% Replacement parts: All parts in-stock, 24 hours a day with same day shipping available.

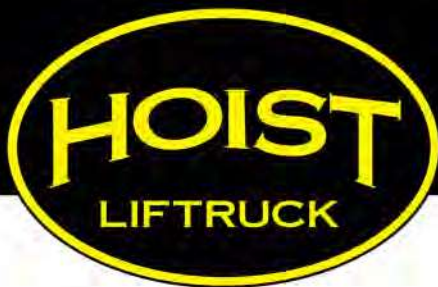

# FR 25/35 RATINGS

## CAPACITIES (Lbs) WITH 0 COUNTERWEIGHT SLABS

FORKS ONLY	COUNTERWEIGHT EXTENSION (in)			
	0"	12"	24"	36"
24" LC	16,500	19,100	21,600	24,200
36" LC	13,200	15,300	17,300	19,400
48" LC	11,000	12,700	14,400	16,200
60" LC	9,500	10,900	12,400	13,900
72" LC	8,200	9,500	10,800	12,000
84" LC	7,300	8,400	9,600	10,700

BOOM ONLY	COUNTERWEIGHT EXTENSION (in)			
	0"	12"	24"	36"
12" LC	15,700	18,300	20,900	23,400
24" LC	12,500	14,500	16,700	18,700
36" LC	10,400	12,100	13,900	15,600
48" LC	8,900	10,400	12,000	13,400
60" LC	7,800	9,100	10,500	11,800
72" LC	7,000	8,100	9,200	10,400
84" LC	6,300	7,300	8,300	9,300
96" LC	5,700	6,600	7,600	8,500





# FR 25/35 RATINGS

## CAPACITIES (Lbs) WITH 1 COUNTERWEIGHT SLABS

FORKS ONLY	COUNTERWEIGHT EXTENSION (in)			
	0"	12"	24"	36"
24" LC	17,830	20,670	23,380	26,200
36" LC	14,270	16,530	18,700	20,980
48" LC	11,900	13,730	15,580	17,500
60" LC	10,250	11,780	13,400	15,020
72" LC	8,870	10,270	11,680	13,000
84" LC	7,880	9,080	10,370	11,580

BOOM ONLY	COUNTERWEIGHT EXTENSION (in)			
	0"	12"	24"	36"
12" LC	17,030	19,870	22,670	25,420
24" LC	13,580	15,770	18,100	20,300
36" LC	11,300	13,150	15,070	16,920
48" LC	9,680	11,300	13,000	14,520
60" LC	8,480	9,880	11,370	12,770
72" LC	7,580	8,780	9,980	11,280
84" LC	6,830	7,920	9,000	10,080
96" LC	6,180	7,170	8,230	9,220

**Hoist Liftruck Mfg., Inc.**

6499 West 65th Street • Bedford Park, IL 60638

P: 708-458-2200 • F: 708-458-1178

sales@hoistlift.com

www.hoistlift.com

**www.hoistlift.com**



# FR 25/35 RATINGS

## CAPACITIES (Lbs) WITH 2 COUNTERWEIGHT SLABS

FORKS ONLY	COUNTERWEIGHT EXTENSION (in)			
	0"	12"	24"	36"
24" LC	19,170	22,230	25,170	28,200
36" LC	15,330	17,770	20,100	22,570
48" LC	12,800	14,770	16,770	18,800
60" LC	11,000	12,670	14,400	16,130
72" LC	9,530	11,030	12,570	14,000
84" LC	8,470	9,770	11,130	12,470

BOOM ONLY	COUNTERWEIGHT EXTENSION (in)			
	0"	12"	24"	36"
12" LC	18,370	21,430	24,430	27,430
24" LC	14,670	17,030	19,500	21,900
36" LC	12,200	14,200	16,230	18,230
48" LC	10,470	12,200	14,000	15,630
60" LC	9,170	10,670	12,230	13,730
72" LC	8,170	9,470	10,770	12,170
84" LC	7,370	8,530	9,700	10,870
96" LC	6,670	7,730	8,870	9,930

**Hoist Liftruck Mfg., Inc.**

6499 West 65th Street • Bedford Park, IL 60638

P: 708-458-2200 • F: 708-458-1178

sales@hoistlift.com

www.hoistlift.com

[www.hoistlift.com](http://www.hoistlift.com)





# FR 25/35 RATINGS

## CAPACITIES (Lbs) WITH 3 COUNTERWEIGHT SLABS

FORKS ONLY	COUNTERWEIGHT EXTENSION (in)			
	0"	12"	24"	36"
24" LC	20,500	23,800	26,950	30,200
36" LC	16,400	19,000	21,500	24,150
48" LC	13,700	15,800	17,950	20,100
60" LC	11,750	13,550	15,400	17,250
72" LC	10,200	11,800	13,450	15,000
84" LC	9,050	10,450	11,900	13,350

BOOM ONLY	COUNTERWEIGHT EXTENSION (in)			
	0"	12"	24"	36"
12" LC	19,700	23,000	26,200	29,450
24" LC	15,750	18,300	20,900	23,500
36" LC	13,100	15,250	17,400	19,550
48" LC	11,250	13,100	15,000	16,750
60" LC	9,850	11,450	13,100	14,700
72" LC	8,750	10,150	11,550	13,050
84" LC	7,900	9,150	10,400	11,650
96" LC	7,150	8,300	9,500	10,650

**Hoist Liftruck Mfg., Inc.**

6499 West 65th Street • Bedford Park, IL 60638

P: 708-458-2200 • F: 708-458-1178

sales@hoistlift.com

www.hoistlift.com

**www.hoistlift.com**



# FR 25/35 RATINGS

## CAPACITIES (Lbs) WITH 4 COUNTERWEIGHT SLABS

FORKS ONLY	COUNTERWEIGHT EXTENSION (in)			
	0"	12"	24"	36"
24" LC	21,830	25,370	28,730	32,200
36" LC	17,470	20,230	22,900	25,730
48" LC	14,600	16,830	19,130	21,400
60" LC	12,500	14,430	16,400	18,370
72" LC	10,870	12,570	14,330	16,000
84" LC	9,630	11,130	12,670	14,230

BOOM ONLY	COUNTERWEIGHT EXTENSION (in)			
	0"	12"	24"	36"
12" LC	21,030	24,570	27,970	31,470
24" LC	16,830	19,570	22,300	25,100
36" LC	14,000	16,300	18,570	20,870
48" LC	12,030	14,000	16,000	17,870
60" LC	10,530	12,230	13,970	15,670
72" LC	9,330	10,830	12,330	13,930
84" LC	8,430	9,770	11,100	12,430
96" LC	7,630	8,870	10,130	11,370

**Hoist Liftruck Mfg., Inc.**

6499 West 65th Street • Bedford Park, IL 60638

P: 708-458-2200 • F: 708-458-1178

sales@hoistlift.com

www.hoistlift.com

**www.hoistlift.com**





# FR 25/35 RATINGS

## CAPACITIES (Lbs) WITH 5 COUNTERWEIGHT SLABS

FORKS ONLY	COUNTERWEIGHT EXTENSION (in)			
	0"	12"	24"	36"
24" LC	23,170	26,930	30,520	34,200
36" LC	18,530	21,470	24,300	27,320
48" LC	15,500	17,870	20,320	22,700
60" LC	13,250	15,320	17,400	19,480
72" LC	11,530	13,330	15,220	17,000
84" LC	10,220	11,820	13,430	15,120

BOOM ONLY	COUNTERWEIGHT EXTENSION (in)			
	0"	12"	24"	36"
12" LC	22,370	26,130	29,730	33,480
24" LC	17,920	20,830	23,700	26,700
36" LC	14,900	17,350	19,730	22,180
48" LC	12,820	14,900	17,000	18,980
60" LC	11,220	13,020	14,830	16,630
72" LC	9,920	11,520	13,120	14,820
84" LC	8,970	10,380	11,800	13,220
96" LC	8,120	9,430	10,770	12,080





# FR 25/35 RATINGS

## CAPACITIES (Lbs) WITH 6 COUNTERWEIGHT SLABS

FORKS ONLY	COUNTERWEIGHT EXTENSION (in)			
	0"	12"	24"	36"
24" LC	24,500	28,500	32,300	36,200
36" LC	19,600	22,700	25,700	28,900
48" LC	16,400	18,900	21,500	24,000
60" LC	14,000	16,200	18,400	20,600
72" LC	12,200	14,100	16,100	18,000
84" LC	10,800	12,500	14,200	16,000

BOOM ONLY	COUNTERWEIGHT EXTENSION (in)			
	0"	12"	24"	36"
12" LC	23,700	27,700	31,500	35,500
24" LC	19,000	22,100	25,100	28,300
36" LC	15,800	18,400	20,900	23,500
48" LC	13,600	15,800	18,000	20,100
60" LC	11,900	13,800	15,700	17,600
72" LC	10,500	12,200	13,900	15,700
84" LC	9,500	11,000	12,500	14,000
96" LC	8,600	10,000	11,400	12,800