

# RTG 8030

**II**  
SERIES  
**II**

## Rough Terrain Crane 30-ton (30.0 mt)

- 29–91.3 (8.8–27.8m) four-section "diamond embossed" full power boom with quick reeve boom head
- Two boom extend modes: A-max and standard boom lifting capacities
- Optional 25 ft (7.6m) fixed fly
- Optional 27–44 ft (8.2–13.4m) two-piece fly with offset of 2°, 20°, and 40°
- 143 ft (43.6m) maximum tip height
- No deducts for stowed attachments
- 11,948 lbs (5 420kg) maximum winch line pull
- 452 fpm (138m/min) maximum winch line speed
- Pilot-operated hydraulic controllers
- 4x2 and 4x4 drive with 20.5R25 tires
- Three steering modes: independent front, combination, and crab
- 6-speed power shift transmission
- 4-link rear suspension with optional Hydro-gas ride

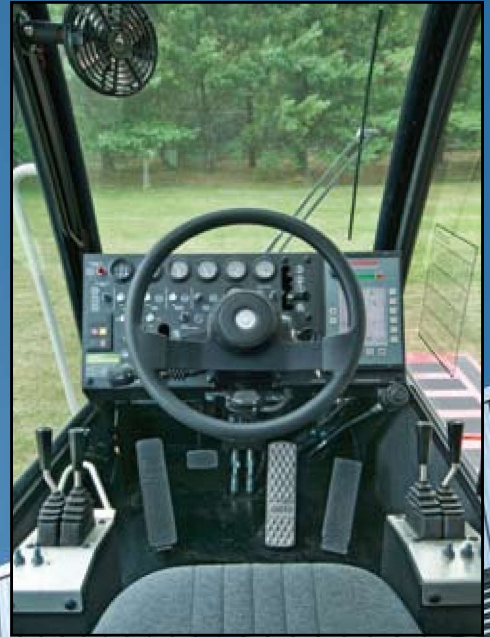

**Link-Belt**  
CRANES

# RTG 8030 SERIES II

## Rough Terrain Crane 30-ton (30.0 mt)

### Remarkable control, reliability and capacity performance

- Powerful diesel engine and direct coupled transmission
- Hydraulic disc brakes for both service brakes and parking brake
- Weather proof electrical connectors and relays throughout for outstanding long-term reliability
- Color coded and numbered wiring is protected by a flame retardant polyethylene insulation
- Full lighting package includes cab lights, headlights, turn indication, marker, backup, and stop
- Powder-coated tubing is utilized throughout the crane
- Pre-painted components and plated hardware
- O-ring face sealed hydraulic components with staggered fittings
- Well organized electrical and hydraulic routings throughout

### Full power boom with attachment flexibility

- Quick reeve boom head eliminates the need to remove the becket when it becomes necessary to change the reeving
- Two extend modes: A-max enhances the structural capability and fully synchronized for normal operation
- Available two piece bi-folding lattice fly allows the tip section to be stored thus enhancing the lifting performance when using the base section
- Three available fly options that feature multiple offset positions of 2°, 20°, and 40°
- No deducts for stowed attachments



Engine hood design provides easy access for maintenance.



### Powerful hydraulics

- Piston winch motor provide smooth and precise hoisting
- Provisions for the future installation of the auxiliary winch are standard
- Main and the available auxiliary winch are equally matched in size and performance

### Operator's cab features

- Extra large windows throughout for excellent visibility
- Excellent ventilation via a large sliding door, side and rear windows, and hinged roof window
- 6-way adjustable seat
- Single or dual axis, pilot operated controller mounted on armrest of outstanding operator comfort
- All gauges, switches, indicators, and controls are located in the operator's forward line of sight
- All gauges and switches are backlit for excellent visibility in low light conditions
- Integral rated capacity limiter aids operator in safe and efficient operation
- In cab comfort is maintained by the standard heater
- Available - Internal and external rated capacity limiter light bars
- Available - Integrated air conditioning utilizes the same ventilation outlets as the standard heating system
- Available - cab mounted warning lights

### Transport and jobsite maneuverability

- Folding front and rear ladders to prevent damage during loading and unloading for transport
- Rugged, lightweight steel pontoons with storage locations for transport
- Steering modes are chosen and performed with the steering wheel and include independent front, combination, and "crab"
- 4-Link suspension on the rear axle with an optional Hydro-Gas Ride™ system
- Wide profile lug-type tires for excellent traction in muddy and sanding conditions
- CALC—Outrigger beams extend to three different positions (retracted, intermediate, and fully extended) providing lifting capacities in confined areas



A-max extends only the inner-mid section of the boom for substantially increased capacities for in-close, maximum capacity lifts.



### Designed for easy access and service

- Full-length flat deck with integrated steps and handholds
- Lockable engine compartment
- Large swing out engine hood doors for ease of service
- Filters and serviceable items are easy to access

Link-Belt Construction Equipment Company - Lexington, Kentucky  
www.linkbelt.com

© Link-Belt is a registered trademark. Copyright 2009. All rights reserved. We reserve the right to change designs and specifications at any time. Litho in U.S.A. 9/09 #4366 (supersedes #4353)



# Technical Data

## Specifications & Capacities

# RTC 8030

**Series II**  
**Telescopic Boom Rough Terrain Crane**  
**30 US ton**  
**30 metric ton**

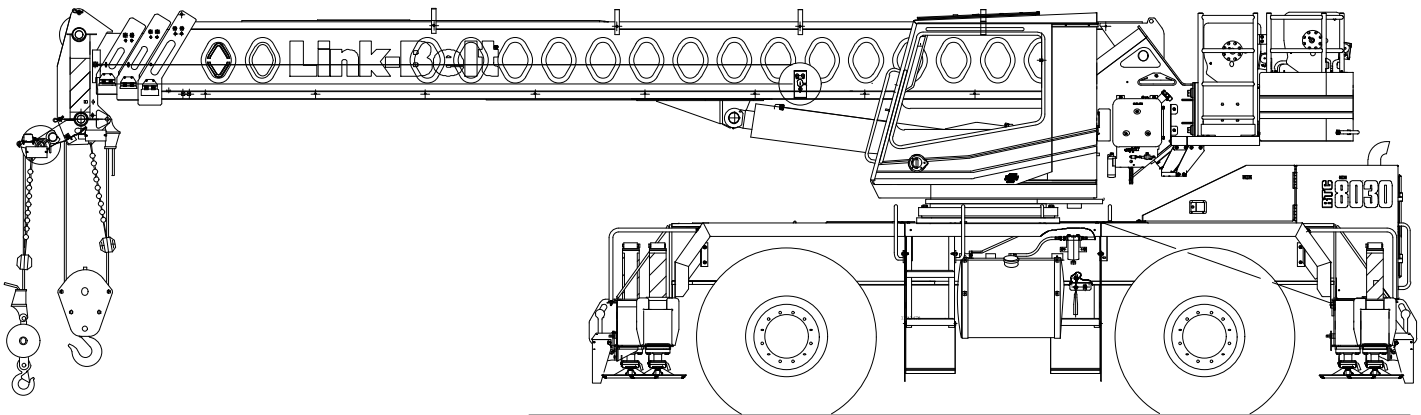

**CAUTION:** This material is supplied for reference use only. Operator must refer to in-cab Crane Rating Manual and Operator's Manual to determine allowable crane lifting capacities and assembly and operating procedures.



# Table Of Contents

<b>Boom, Attachments, and Upper Structure</b> .....	<b>1</b>
Boom .....	1
Boom Head .....	1
Boom Elevation .....	1
Auxiliary Lifting Sheave – Optional .....	1
Hook Blocks and Balls – Optional .....	1
Fly – Optional .....	1
Operator’s Cab and Controls .....	1
Swing .....	2
Electrical .....	2
Load Hoist System .....	3
Load Hoist Performance .....	3
2M Main and Optional Auxiliary Winches .....	3
Hydraulic System .....	3
Counterweight .....	3
<b>Carrier</b> .....	<b>4</b>
General .....	4
Outriggers .....	4
Steering and Axles .....	4
Suspension .....	4
Tires and Wheels .....	4
Brakes .....	4
Electrical .....	4
Engine .....	4
Transmission .....	4
Carrier Speeds and Gradeability .....	5
Fuel Tank .....	5
Hydraulic System .....	5
Pump Drive .....	5
<b>Axle Loads</b> .....	<b>6</b>
<b>General Dimensions</b> .....	<b>7</b>
<b>Working Range Diagram</b> .....	<b>8</b>
<b>Boom Extend Modes</b> .....	<b>9</b>
<b>Main Boom Lift Capacity Charts – Standard</b> .....	<b>10</b>
Fully Extended Outriggers – 360° Rotation .....	10
On Tires – Stationary – Boom Centered Over Front Between Tire Tracks .....	11
On Tires – Pick & Carry (Creep) – Boom Centered Over Front .....	11
On Tires – Stationary – 360° Rotation .....	11
<b>Fly Attachment Lift Capacity Charts – Optional</b> .....	<b>12</b>
Fully Extended Outriggers – 360° Rotation .....	12
Fully Extended Outriggers – 360° Rotation .....	13

<b>Main Boom Lift Capacity Charts – Optional (Metric)</b> .....	<b>14</b>
Fully Extended Outriggers – 360° Rotation .....	14
On Tires – Stationary – Boom Centered Over Front Between Tire Tracks .....	15
On Tires – Pick & Carry (Creep) – Boom Centered Over Front .....	15
On Tires – Stationary – 360° Rotation .....	16
<b>Fly Attachment Lift Capacity Charts – Optional (Metric)</b> .....	<b>16</b>
Fully Extended Outriggers – 360° Rotation .....	16
Fully Extended Outriggers – 360° Rotation .....	17

# Boom, Attachments, and Upper Structure

## ■ Boom

**Design** — Four section, box type construction of high tensile steel consisting of one base section and three telescoping sections. The vertical side plates have diamond shaped steel impressions for superior strength to weight ration. The first telescoping section extends independently by means of one double—acting, single stage hydraulic cylinder with integrated holding valves. The second and third telescoping sections extend proportionally by means of one double—acting, single stage cylinder with integrated holding valves and cables.

## Boom

- 29 ft—91 ft 4 in (8.84—27.84m) four section full power boom
- Two mode boom extension: *A—max* mode provides superior capacities by extending the first telescoping section to 49 ft 9 in (15.16m). Standard mode synchronizes all the telescoping sections proportionally to 91 ft 4 in (27.84m). Controlled from the operator's cab.
- Mechanical boom angle indicator
- Maximum tip height for *A—max* mode is 66 ft 2 in (20.2m) and standard mode is 100 ft 6 in (30.6m).

## Boom Head

- Four 10.63 in (27.0cm) root diameter nylon sheaves to handle up to eight parts of line
- Easily removable wire rope guards
- Rope dead end lugs on each side of the boom head
- Boom head is designed for quick—reeve of the hook block

## Boom Elevation

- One double acting hydraulic cylinder with integral holding valve
- Boom elevation:  $-3^{\circ}$  to  $78^{\circ}$

## Auxiliary Lifting Sheave — Optional

- Single 10.63 in (27.0cm) root diameter steel sheave
- Easily removable wire rope guards
- Does not affect erection of the fly or use of the main head sheaves

## Hook Blocks and Balls — Optional

- 30 ton (27.2mt) 3 sheave quick—reeve hook block with safety latch
- 8.5 ton (7.7mt) swivel and non—swivel hook balls with safety latch

## Fly — Optional

- 25 ft (7.62m) one piece lattice fly, stowable. Maximum tip height is 124.63 ft (37.99m).
- 27 ft (8.23m) one piece lattice fly, stowable, offsettable to  $2^{\circ}$ ,  $20^{\circ}$ , and  $40^{\circ}$ . Maximum tip height is 126.33 ft (38.51m).

- 27—44 ft (8.23—13.41m) two piece bi—fold lattice fly, stowable, offsettable to  $2^{\circ}$ ,  $20^{\circ}$ , and  $40^{\circ}$ . Maximum tip height is 143.11 ft (43.62m).

## ■ Operator's Cab and Controls

**Environmental Cab** — Fully enclosed, one person cab of galvaneal steel structure with acoustical insulation.

Equipped with:

- Tinted and tempered glass windows
- Large fixed front window with windshield wiper and washer
- Swing up roof window with windshield wiper
- Sliding left side door with large fixed window
- Sliding rear and right side windows for ventilation
- Six way adjustable, cushioned seat with seat belt
- Diesel fired warm—water heater with air ducts for front windshield defroster and cab floor
- 12 volt accessory outlet
- Bubble level
- Circulating fan
- Adjustable sun visor
- Dome light
- Cup holder
- Fire extinguisher
- Mirrors
- Emergency steering system — optional

**Air Conditioning** — Optional

**Engine Dependent Heater — Optional** — Flameless, warm—water system that does not have a separate fuel tank

**Steering Column** — Conventional automotive type with tilt and telescope functions for operator comfort. Steering column includes the following controls and indicators:

- Tilt lever
- Turn signal lever
- Windshield wiper and washer switch
- Headlight switch
- Telescoping column lock
- Steering wheel
- Horn button
- Engine ignition switch
- Ignition switch lock
- Hazard flasher button

**Armrest Controls** — Two single axis controllers for:

- Swing
- Boom hoist
- Main rear winch
- Auxiliary front winch — optional
- Drum rotation indication
- Drum rotation indicator activation switch
- Winch high/low speed and disable switch(es)
- Throttle lock
- Telescopic override switches

**Foot Controls**

- Boom telescope
- Swing brake
- Engine throttle
- Carrier service brake

**Dash Panel**

Controls for:

- Combination steering
- 4—wheel drive
- Transmission gear selection
- Rated capacity limiter
- Two position swing lock
- Swing park brake
- Function lockout
- Outtrigger system
- Upper lights — optional
- Rotating beacon — optional
- Ether start — optional
- Air conditioner and heater — optional
- Third wrap indicator activation — optional
- Boom floodlight — optional

Indicators for:

- Service brake
- Rear wheel offset
- First layer/Third wrap — optional

Gauges for:

- Fuel level
- Hydraulic oil temperature
- Voltage indicator
- Water temperature
- Engine oil pressure
- Tachometer
- Transmission oil temperature

**Camera Display** — Located on dash console

- Displays right side of upper
- Displays main and auxiliary winches

**Rated Capacity Limiter** — Microguard graphic audio—visual warning system integrated into the dash with anti—two block and function limiter. Operating data available includes:

- Crane configuration
- Boom length
- Boom head height
- Allowed load and % of allowed load
- Boom angle
- Radius of load
- Actual load
- Operator settable alarms (include):
  - Maximum and minimum boom angles
  - Maximum tip height
  - Maximum boom length
  - Swing left/right positions
  - Operator defined area (imaginary plane)

**Internal RCL Light Bar — Optional** — Visually informs the operator when crane is approaching maximum load capacity with a series of green, yellow, and red lights.

**External RCL Light Bar — Optional** — Visually informs the ground crew when crane is approaching maximum load capacity with a series of green, yellow, and red lights.

**■ Swing**

**Motor/Planetary** — Bi—directional hydraulic swing motor mounted to a planetary reducer for 360° continuous smooth swing at 2.8 rpm.

**Swing Park Brake** — 360°, mechanical disc brake mounted on the speed reducer. Mechanically controlled from the operator's cab.

**Swing Brake** — 360°, foot operated, hydraulic applied disc brake mounted to the speed reducer.

**Swing Lock** — Two—position swing lock (boom over front or rear) operated from the operator's cab.

**360° Positive Swing Lock — Optional** — Meets New York City requirement.

**■ Electrical**

**Swing Alarm** — Audio warning device signals when the upper is swinging.

**Lights**

- Two working lights on front of the cab — optional
- One rotating amber beacon on top of the cab — optional
- One amber strobe beacon on top of the cab — optional
- Boom floodlight — Single — optional
- Boom floodlight — Dual — optional
- Boom floodlight — High intensity remote controlled — optional



## ■ Load Hoist System

### Load Hoist Performance

Main (Rear) and Auxiliary (Front) Winches — 5/8 in (16mm) Rope										
Layer	Maximum Line Pull		Normal Line Speed		High Line Speed		Layer		Total	
	lb	kg	ft/min	m/min	ft/min	m/min	ft	m	ft	m
1	11,948	5 419.5	174	53.0	318	96.9	77	23.5	77	23.5
2	10,807	4 902.0	192	58.5	352	107.3	84	25.6	161	49.1
3	9,866	4 475.1	210	64.0	385	117.3	93	28.3	254	77.4
4	9,075	4 116.4	229	69.8	419	127.7	101	30.8	355	108.2
5	8,401	3 810.6	247	75.3	452	137.8	109	33.2	464	141.4
6	—	—	—	—	—	—	117	35.6	581	177.1

Wire Rope Application		Diameter		Type	Maximum Permissible Load	
		in	mm		lb	kg
Main (Rear) Winch	Standard	5/8	16	6x19 I.W.R.C. — Right Regular Lay (Type DB)	11,770	5 338.8
	Optional	5/8	16	18x19 Rotation Resistant — Right Regular Lay (Type RB)	9,080	4 118.6
Auxiliary (Front) Winch	Standard	5/8	16	6x19 I.W.R.C. — Right Regular Lay (Type DB)	11,770	5 338.8
	Optional	5/8	16	18x19 Rotation Resistant — Right Regular Lay (Type RB)	9,080	4 118.6

### 2M Main and Optional Auxiliary Winches

- Bi-directional gear-type (2-speed) hydraulic motors driven through planetary reduction unit for positive control under all load conditions.
- Grooved lagging
- Power up/down mode of operation
- Hoist drum cable follower
- Drum rotation indicator
- Drum diameter: 10.63 in (27.00cm)
- Rope length:
  - Main: 450 ft (137.1m)
  - Auxiliary: 450 ft (137.1m)
- Maximum rope storage: 581 ft (177.1m)
- Terminator style socket and wedge

**Integrated Third Wrap Indicator — Optional —** Visually and audibly warns the operator when the wire rope is on the first/bottom layer and when the wire rope is down to the last three wraps.

**Integrated Third Wrap Function Kickout — Optional —** Visually and audibly warns the operator when the wire rope is on the first/bottom layer and provides a function kickout when the wire rope is down to the last three wraps.

### ■ Hydraulic System

**Counterbalance Valves** — All hoist motors, boom extend cylinders, and boom hoist cylinders are equipped with counterbalance valves to provide load lowering and prevents accidental load drop when hydraulic power is suddenly reduced.

### ■ Counterweight

Total of 9,300 lb (4 218kg) of counterweight bolted to the upper structure frame.

## Carrier

### General

- 8 ft 6 in (3.31m) wide
- 11 ft 5 in (3.48m) wheelbase (centerline of first axle to centerline of second axle).

**Frame** — Box—type, torsion resistant, welded construction made of high tensile steel. Equipped with front towing shackles, pontoon storage brackets, hook block tie back, and front, rear, and side carrier steps.

### Outriggers

**Boxes** — Two double box, front and rear welded to carrier frame.

**Beams and Jacks** — Four single stage beams with Confined Area Lifting Capacities (CALC™) provide selectable outrigger extensions of full, intermediate, and retracted. Hydraulically controlled from the operator's cab with integral check valves.

**Pontoons** — Four lightweight, quick release, 18.77 x 18.77 in (47.67 x 47.67cm) steel pontoons with contact area of 352 in<sup>2</sup> (2 270.9cm<sup>2</sup>) can be stored for road travel in storage racks on the carrier.

**Main Jack Reaction** — 50,000 lb (22 679.6kg) force and 173 psi (1 116.0kPa) ground bearing pressure.

### Steering and Axles

**Steering** — Three independent modes consisting of conventional two wheel front, four wheel, and crab. Each mode is selected by a switch on the dash and fully controlled by the steering wheel.

**Drive** — Two modes: 4 x 2 and 4 x 4 for off highway travel

**Axle 1** — Steered, non—driven for 4 x 2 and steered, driven for 4 x 4

**Axle 2** — Steered, driven

### Suspension

**Front** — Rigid mount to the carrier frame

**Rear** — The rear axle is suspended on the oscillation cylinders with motion of the axle controlled by a four bar linkage system. The oscillation cylinders lockout when the upper structure rotates 2.5° past centerline.

- Hydro—gas rear suspension — optional

### Tires and Wheels

**Front and Rear** — Four (single) 20.5R25, 24 ply rating, loader type tires on steel disc wheels

- Spare tires and wheels — optional

### Brakes

**Service** — Full hydraulic, dual circuit, disc type brakes on all wheel ends with independent front and rear system

**Parking/Emergency** — Spring applied, hydraulic released, cab controlled, disc type integral to the transmission

### Electrical

Two batteries provide 12 volt operation and starting

#### Lights

- Front lighting includes two main headlights, and two parking/directional indicators
- Rear lighting includes two parking/directional indicators, two parking/brake lights, and two reversing lights
- Other equipment includes hazard/warning system, cab light, dash panel lighting, and signal horn

### Engine

Specification	CAT C6.6
Numbers of Cylinders	6
Cycle	4
Bore and Stroke: inch (mm)	4.13 x 5.00 (105 x 127)
Piston Displacement: in <sup>3</sup> (L)	402.7 (6.6)
Max. Brake Horsepower: hp (kW)	164 (122.2) @ 1,800 rpm
Peak Torque: ft lb (Nm)	504 (683) @ 1,500 rpm
Alternator: volts — amps	12 — 150
Crankcase Capacity: qt (L)	18.4 (17.4)
<ul style="list-style-type: none"> <li>• Mechanically driven fan and thermostatically controlled radiator</li> <li>• Water/Fuel separator</li> <li>• 110—volt block heater</li> <li>• Glow plugs/block heater</li> </ul>	

### Transmission

**Powershift** — Three speed with high/low range for 6 forward and 2 reverse gears. Front axle disconnect for two or four wheel drive. Front axle disconnects in high range.

## ■ Carrier Speeds and Gradeability

Dana Spicer		Ratio	Speed		Gradeability (@ 70% Converter efficiency)
Gear			mph	km/h	% Grade
6th	Forward 2WD Hi	0.704	17.4	28.00	2.3
5th		2.111	8.9	14.32	10.9
4th		4.825	4.0	6.43	28.3
3rd	Forward 4WD Low	1.576	11.6	18.66	7.6
2nd		4.727	4.0	6.43	27.6
1st		10.805	1.8	2.89	82.1
2nd	Reverse 2WD	4.825	4.0	6.43	28.3
1st	Reverse 4WD	10.805	1.8	2.89	82.1

Based on a gross vehicle weight of 58,500 lb (26 535kg).  
Crane operating angle must not exceed 25° (47% grade).

## ■ Fuel Tank

One 75 gallon (283.9L) capacity tank

## ■ Hydraulic System

All functions are hydraulically powered allowing positive precise, control.

### Main Pumps

- One two section fixed displacement gear pump for the front/rear winches and boom hoist/telescope circuits.
- One single section fixed displacement gear pump for the steering/swing/outriggers/service brake circuit.
- Combined pump capacity of 93 gpm (352.0Lpm).

**Hydraulic Reservoir** – 80 gal (303L) capacity equipped with sight level gauge. Diffusers built in for deaeration.

**Filtration** – Two 10 micron, full flow, line filter in the control circuit. All oil is filtered prior to return to sump tank. Accessible for easy filter replacement.

## ■ Pump Drive

All pumps are mechanically driven by the diesel engine.

- Front /rear winches, boom hoist, and telescope pumps are mounted to a mechanical pump disconnect on the transmission torque converter to aid in cold weather starting.

# Axle Loads

Base crane with full tank of fuel	Gross Vehicle Weight <sup>(1)</sup>		Upper Facing Front				Upper Facing Rear			
			Front Axles		Rear Axles		Front Axles		Rear Axles	
	lb	kg	lb	kg	lb	kg	lb	kg	lb	kg
	55,526	25 186	27,561	12 501	27,965	12 685	25,238	11 448	30,288	13 738
Cold weather starting aids — ether injection	6	3	0	0	6	3	0	0	6	3
Pintle hook, front and rear	26	12	13	6	13	6	13	6	13	6
Pump disconnect	28	13	6	3	21	10	6	3	21	10
Power up/down winch with 450 ft (137.1m) wire rope — front	361	164	-28	-13	389	176	402	182	-41	-19
Winch roller — rear winch	76	34	-14	-6	90	41	93	42	-17	-8
Winch roller — front winch	76	36	1	0	75	34	78	35	-2	-1
Remove 450 ft (137.1m) wire rope from rear winch	-320	-145	82	37	-402	-182	-413	-187	94	43
Remove 450 ft (137.1m) wire rope from front winch	-320	-145	21	10	-340	-154	-352	-160	33	15
Air conditioning in operator's cab	215	98	36	16	179	81	187	85	28	13
360° swing lock	60	27	29	13	31	14	33	15	27	12
Emergency steer system	5	2	3	1	2	1	2	1	3	1
Fly storage brackets to boom base section for fly options	140	64	200	91	-60	-27	-55	-25	195	88
25 ft (7.62m) fixed fly — stowed	535	243	813	369	-278	-126	-259	-117	794	360
27 ft (8.23m) offset fly — stowed	1,052	477	1,701	772	-649	-294	-611	-277	1,663	754
27—44 ft (8.23—13.41m) offset fly — stowed	1,475	669	2,184	991	-710	-322	-656	-298	2,131	967
Floodlight to boom base section	4	2	7	3	-3	-1	-3	-1	7	3
30 ton (27.2mt) hook block to carrier storage box	670	304	943	428	-273	-124	-248	-112	918	416
8.5 ton (7.7mt) hook block to carrier storage box	360	163	506	230	-146	-66	-133	-60	493	225
Auxiliary lifting sheave	71	32	197	82	-126	-57	-124	-56	195	88

Tire	Maximum Load @ 25 mph (40.2km/h)
20.5R25 (24—PR)	16,125 lb (7 314kg)

(1) Adjust gross vehicle weight and axle loading according to component weight.  
 Note: All weights are ±3%.

# General Dimensions

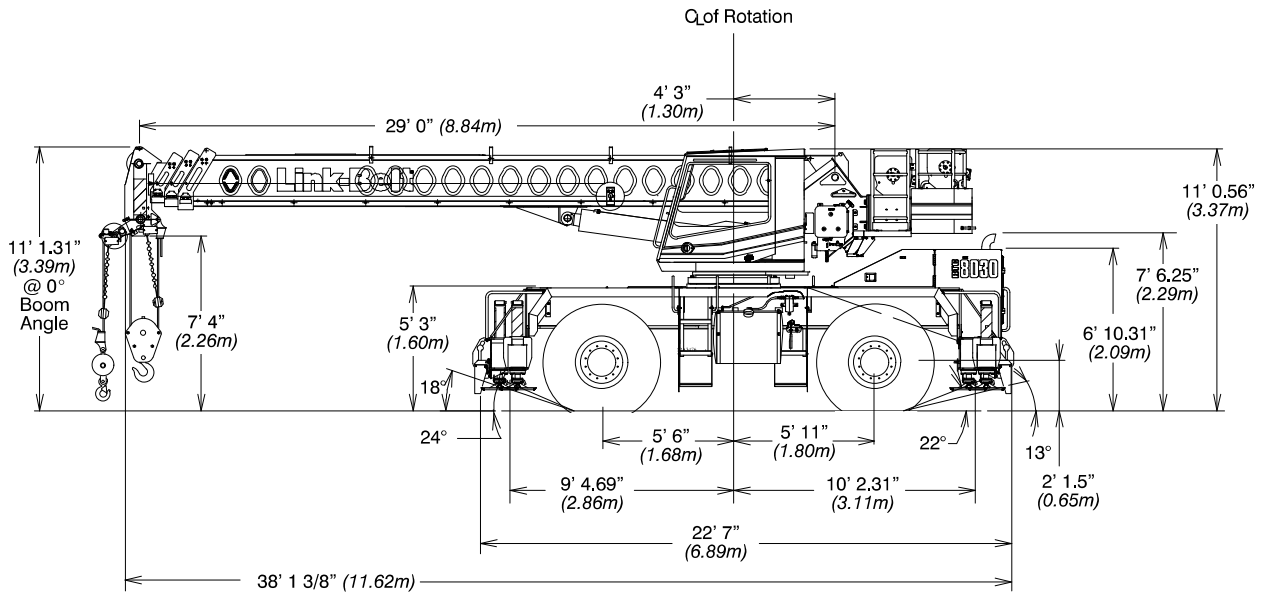

Turning Radius — Front Wheel (4x2) Steering	English	Metric
Wall to wall over carrier	35'	10.67m
Wall to wall over boom attachment	43' 1"	13.13m
Curb to curb	33' 2"	10.11m
Centerline of tire	31' 8"	9.64m

Turning Radius — All Wheel (4x4) Steering	English	Metric
Wall to wall over carrier	20' 8"	6.31m
Wall to wall over boom attachment	30' 2"	9.20m
Curb to curb	18' 9"	5.71m
Centerline of tire	17' 1"	5.21m

Tail Swing	English	Metric
With counterweight	9' 11.5"	3.04m
Without counterweight	N/A	N/A

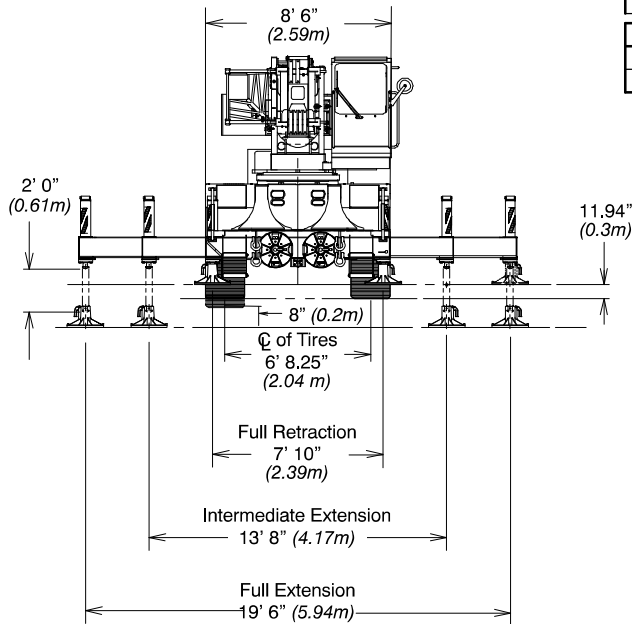

Not To Scale

# Working Range Diagram

## Working Range Diagram On Fully Extended Outriggers

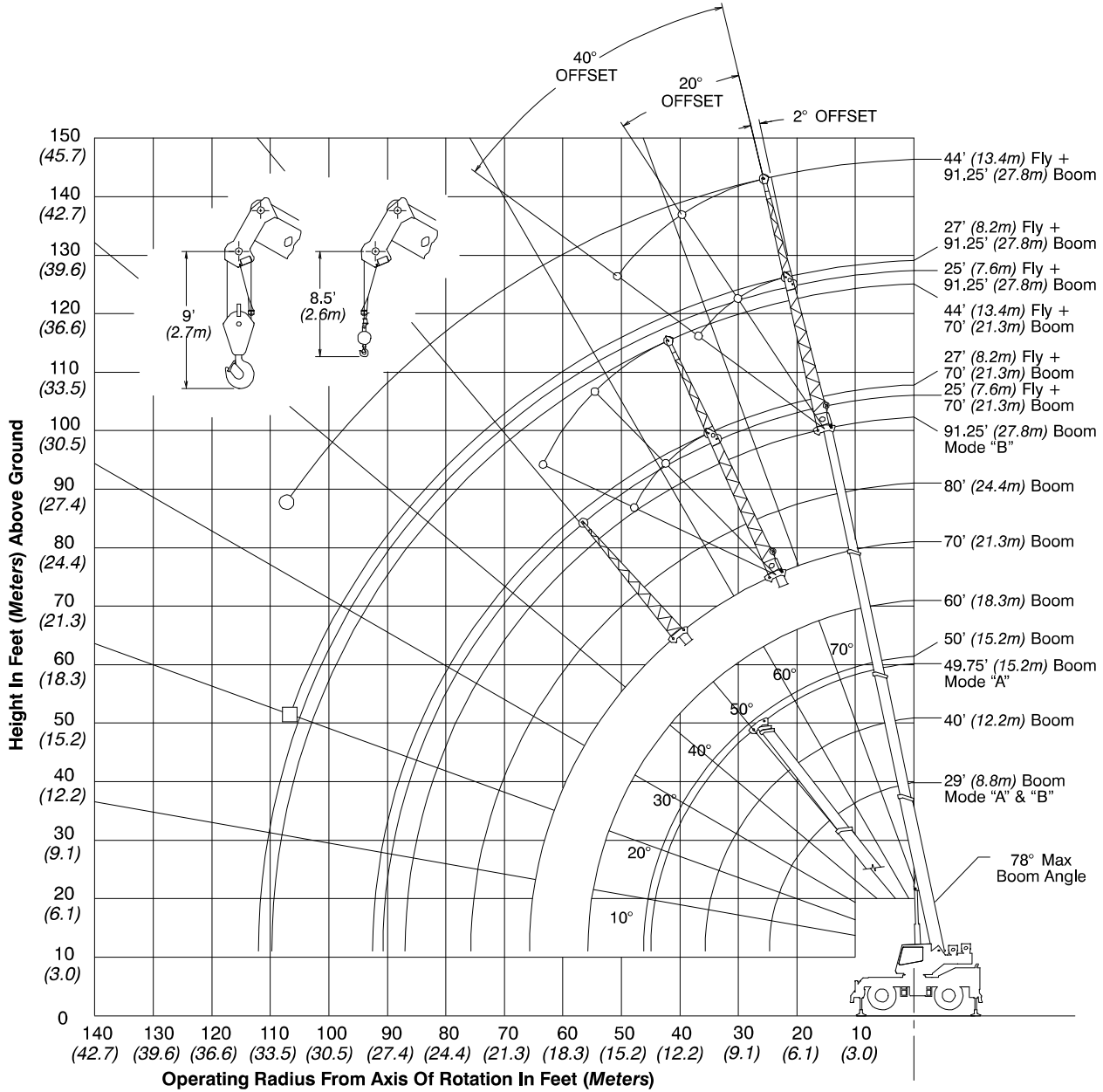
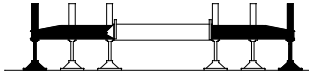

- Denotes Main Boom + 44' (13.4m) Offset Fly—Boom Mode "B"
- Denotes Main Boom + 27' (8.2m) Offset Fly—Boom Mode "B"

# Boom Extend Modes

## Boom Mode “A” (A-max)

Only inner mid section telescopes.

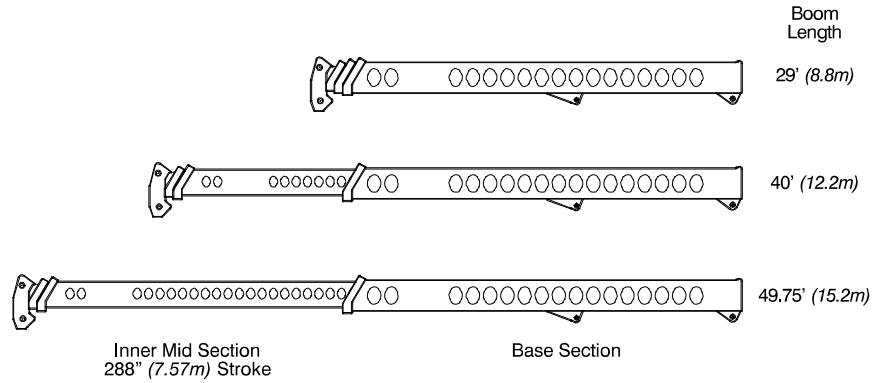

## Boom Mode “B” (Standard)

Inner mid, outer mid, and tip sections telescope simultaneously.

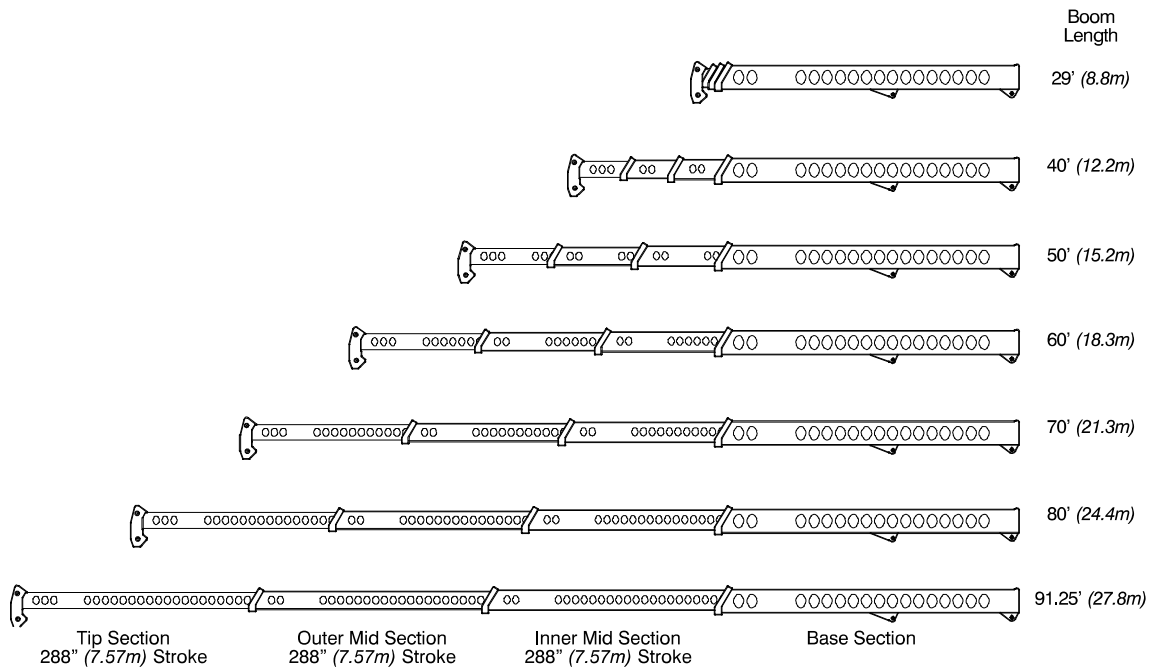

## Main Boom Lift Capacity Charts – Standard

Fully Extended Outriggers – 360° Rotation (All Capacities Are Listed In Pounds)								
Radius (ft)	Boom Length (ft)							Radius (ft)
	29	40	50	60	70	80	91.25	
10	60,000	50,100	31,300					10
12	52,300	47,600	31,300	25,000				12
15	43,000	40,600	31,300	25,000	25,000			15
20	31,200	30,900	27,600	25,000	25,000	25,000	19,000	20
25		24,300	24,600	24,200	22,700	21,400	19,000	25
30		19,200	19,500	19,700	19,100	18,100	16,800	30
35		15,500	15,900	16,100	16,200	15,500	14,700	35
40			12,700	12,900	13,000	13,000	12,800	40
45			10,200	10,400	10,500	10,600	10,700	45
50				8,600	8,700	8,800	8,800	50
55				7,100	7,200	7,300	7,400	55
60					6,100	6,100	6,200	60
65					5,100	5,200	5,200	65
70						4,400	4,400	70
75						3,700	3,800	75
80							3,200	80
85							2,700	85

This information is not for crane operation. Operator must refer to the in-cab information for crane operation. Rated lifting capacities shown on fully extended outriggers do not exceed 85% of the tipping loads and on tires do not exceed 75% of the tipping loads.



**On Tires — Stationary — Boom Centered Over Front Between Tire Tracks**  
(All Capacities Are Listed In Pounds)

Radius (ft)	Boom Length (ft)				Radius (ft)
	29	40	50	60	
10	32,800	25,000			10
12	28,900	28,600			12
15	24,300	24,800			15
20	17,400	18,100	18,300		20
25		12,300	12,600	12,700	25
30		8,800	9,200	9,300	30
35		6,500	6,900	7,100	35
40			5,200	5,400	40
45			4,000	4,200	45
50				3,200	50
55				2,500	55

**On Tires — Pick & Carry (Creep) — Boom Centered Over Front**  
(All Capacities Are Listed In Pounds)

Radius (ft)	Boom Length (ft)				Radius (ft)
	29	40	50	60	
10	31,900	25,000			10
12	27,600	25,000			12
15	22,700	23,200			15
20	17,000	17,500	17,800		20
25		12,300	12,600	12,700	25
30		8,800	9,200	9,300	30
35		6,500	6,900	7,100	35
40			5,200	5,400	40
45			4,000	4,200	45
50				3,200	50
55				2,500	55

**On Tires — Stationary — 360° Rotation**  
(All Capacities Are Listed In Pounds)

Radius (ft)	Boom Length (ft)				Radius (ft)
	29	40	50	60	
10	24,000	24,400			10
12	17,700	18,200			12
15	12,000	12,700			15
20	7,000	7,700	7,900		20
25		4,900	5,200	5,300	25
30		3,100	3,400	3,600	30
35		1,800	2,200	2,400	35

This information is not for crane operation. Operator must refer to the in-cab information for crane operation. Rated lifting capacities shown on fully extended outriggers do not exceed 85% of the tipping loads and on tires do not exceed 75% of the tipping loads.

## Fly Attachment Lift Capacity Charts – Optional

Fully Extended Outriggers – 360° Rotation (All Capacities Are Listed In Pounds)	
91.25 ft Main Boom Length	
Radius (ft)	25 ft Fixed Fly
30	10,200
35	10,200
40	9,800
45	9,200
50	8,400
55	7,700
60	6,900
65	5,900
70	5,100
75	4,400
80	3,800
85	3,300
90	2,900
95	2,500
100	2,100
105	1,800
110	1,500

This information is not for crane operation. Operator must refer to the in-cab information for crane operation. Rated lifting capacities shown on fully extended outriggers do not exceed 85% of the tipping loads and on tires do not exceed 75% of the tipping loads.

Fully Extended Outriggers — 360° Rotation (All Capacities Are Listed In Pounds)								
91.25 ft Main Boom Length 2° Fly Offset			91.25 ft Main Boom Length 20° Fly Offset			91.25 ft Main Boom Length 40° Fly Offset		
Radius (ft)	Fly Length (ft)		Radius (ft)	Fly Length (ft)		Radius (ft)	Fly Length (ft)	
	27	44		27	44		27	44
30	9,900		35	7,200		45	5,000	
35	9,700	6,500	40	6,800		50	4,800	
40	9,300	6,000	45	6,400		55	4,600	
45	8,600	5,500	50	6,100	3,600	60	4,500	2,500
50	7,800	5,100	55	5,800	3,400	65	4,400	2,400
55	7,200	4,700	60	5,500	3,200	70	4,300	2,300
60	6,600	4,400	65	5,200	3,100	75	4,200	2,300
65	5,600	4,100	70	5,000	2,900	80	4,000	2,200
70	4,800	3,800	75	4,400	2,800	85	3,400	2,200
75	4,100	3,600	80	3,800	2,700	90	2,900	2,100
80	3,500	3,400	85	3,200	2,500	95	2,400	2,100
85	3,000	3,200	90	2,800	2,400	100		2,100
90	2,600	2,800	95	2,300	2,400	105		2,100
95	2,200	2,400	100	2,000	2,300	110		1,800
100	1,800	2,000	105	1,600	2,000	115		1,500
105	1,500	1,700	110	1,300	1,700			
110		1,400	115		1,400			

This information is not for crane operation. Operator must refer to the in-cab information for crane operation. Rated lifting capacities shown on fully extended outriggers do not exceed 85% of the tipping loads and on tires do not exceed 75% of the tipping loads.

## Main Boom Lift Capacity Charts – Optional (Metric)

Fully Extended Outriggers – 360° Rotation (All Capacities Are Listed In Kilograms)								
Radius (m)	Boom Length (m)							Radius (m)
	8.84	12.2	15.16/15.2	18.3	21.3	24.4	27.81	
2.5	30 000							3
3	27 220	22 700	14 150**					3
3.5	23 900	22 000	14 150**					3.5
4	22 200	20 300	14 150**	11 300				4
4.5	20 250	18 600	14 150**	11 300				4.5
5	17 900	17 200	14 150**	11 300	11 300			5
6	14 400	14 300	12 700**	11 300	11 300	11 300	8 600	6
7	11 900	11 800	11 300	11 300	10 950	10 400	8 600	7
8		10 350	10 500	10 600	9 850	9 300	8 450	8
9		8 600	8 700	8 800	8 800	8 350	7 700	9
10		7 100	7 250	7 300	7 350	7 350	7 050	10
12			5 250	5 300	5 350	5 350	5 350	12
14				4 000	4 050	4 100	4 100	14
16				3 100	3 150	3 200	3 200	16
18					2 500	2 550	2 550	18
20					2 000	2 000	2 050	20
22						1 600	1 650	22
24							1 300	24
26							1 050	26

\*\* 15.16 A—max Mode

This information is not for crane operation. Operator must refer to the in-cab information for crane operation. Rated lifting capacities shown on fully extended outriggers do not exceed 75% of the tipping loads and on tires do not exceed 65% of the tipping loads.

**On Tires — Stationary — Boom Centered Over Front Between Tire Tracks**  
**(All Capacities Are Listed In Kilograms)**

Radius (m)	Boom Length (m)				Radius (m)
	8.84	12.2	15.2	18.3	
3	15 050	11 300			3
3.5	13 500	11 300			3.5
4	12 250	12 100			4
4.5	11 150	11 300			4.5
5	9 800	10 000			5
6	7 050	7 300	7 400		6
7	5 300	5 600	5 700	5 750	7
8		4 450	4 550	4 600	8
9		3 600	3 700	3 750	9
10		2 900	3 050	3 100	10
12			2 100	2 200	12
14				1 550	14
16				1 100	16

**On Tires — Pick & Carry (Creep) — Boom Centered Over Front**  
**(All Capacities Are Listed In Kilograms)**

Radius (m)	Boom Length (m)				Radius (m)
	8.84	12.2	15.2	18.3	
3	14 650	11 300			3
3.5	13 000	11 300			3.5
4	11 600	11 500			4
4.5	10 450	10 650			4.5
5	9 450	9 650			5
6	7 050	7 300	7 400		6
7	5 300	5 600	5 700	5 750	7
8		4 450	4 550	4 600	8
9		3 600	3 700	3 750	9
10		2 900	3 050	3 100	10
12			2 100	2 200	12
14				1 550	14
16				1 100	16

This information is not for crane operation. Operator must refer to the in-cab information for crane operation. Rated lifting capacities shown on fully extended outriggers do not exceed 75% of the tipping loads and on tires do not exceed 65% of the tipping loads.

<b>On Tires — Stationary — 360° Rotation</b> (All Capacities Are Listed In Kilograms)					
<b>Radius (m)</b>	<b>Boom Length (m)</b>				<b>Radius (m)</b>
	<b>8.84</b>	<b>12.2</b>	<b>15.2</b>	<b>18.3</b>	
3	9 650	9 850			3
3.5	7 450	7 650			3.5
4	5 950	6 200			4
4.5	4 850	5 100			4.5
5	4 050	4 300			5
6	2 850	3 100	3 200		6
7	2 050	2 300	2 400	2 450	7
8		1 700	1 800	1 900	8
9		1 250	1 400	1 450	9
10		900	1 050	1 100	10

## Fly Attachment Lift Capacity Charts — Optional (Metric)

<b>Fully Extended Outriggers — 360° Rotation</b> (All Capacities Are Listed In Kilograms)	
<b>27.81m Main Boom Length</b>	
<b>Radius (m)</b>	<b>7.62m Fixed Fly</b>
9	4 600
10	4 600
12	4 450
14	4 100
16	3 500
18	2 800
20	2 300
22	1 900
24	1 550
26	1 300
28	1 050
30	900
32	700
34	600

This information is not for crane operation. Operator must refer to the in-cab information for crane operation. Rated lifting capacities shown on fully extended outriggers do not exceed 75% of the tipping loads and on tires do not exceed 65% of the tipping loads.

Fully Extended Outriggers — 360° Rotation (All Capacities Are Listed In Kilograms)								
27.81m Main Boom Length 2° Fly Offset			27.81m Main Boom Length 20° Fly Offset			27.81m Main Boom Length 40° Fly Offset		
Radius (m)	Fly Length (m)		Radius (m)	Fly Length (m)		Radius (m)	Fly Length (m)	
	8.23	13.41		8.23	13.41		8.23	13.41
9	4 500		12	3 100		14	2 250	
10	4 500		14	2 850		16	2 150	
12	4 250	2 750	16	2 700	1 600	18	2 050	1 150
14	3 850	2 500	18	2 500	1 500	20	2 000	1 100
16	3 350	2 250	20	2 350	1 400	22	1 950	1 050
18	2 700	2 000	22	1 950	1 300	24	1 650	1 000
20	2 200	1 850	24	1 550	1 200	26	1 350	1 000
22	1 800	1 700	26	1 300	1 150	28	1 100	950
24	1 450	1 550	28	1 050	1 100	30		950
26	1 200	1 300	30	800	1 000	32		850
28	950	1 050	32	650	800	34		650
30	750	850	34		600			
32	600	700						
34		550						

This information is not for crane operation. Operator must refer to the in-cab information for crane operation. Rated lifting capacities shown on fully extended outriggers do not exceed 75% of the tipping loads and on tires do not exceed 65% of the tipping loads.

This Page Intentionally Blank



This Page Intentionally Blank

**Link-Belt Construction Equipment Company**      Lexington, Kentucky      [www.linkbelt.com](http://www.linkbelt.com)

®Link-Belt is a registered trademark. Copyright 2014. We are constantly improving our products and therefore reserve the right to change designs and specifications.